

Installation and Operating Instruction for Integrated Freewheels FXM and FX Type NX, MX and LX

E 08.766e



RINGSPANN GmbH

Schaberweg 30-34
61348 Bad Homburg
Germany

Telephone +49 6172 275-0
Telefax +49 6172 275-275

www.ringspann.com
mailbox@ringspann.com

RINGSPANN	Installation and Operation Instruction for Integrated Freewheels FXM und FX Type NX, MX und LX			E 08.766e	
	Stand: 11.06.2018	Version : 02	gez.: BACC	gepr.: HEUT	Seitenzahl: 12 Seite: 2

Important

Please read these instructions carefully before installing and operating the product. Your particular attention is drawn to the notes on safety.

These installation and operating instructions are valid on condition that the product meets the selection criteria for its proper use. Selection and design of the product is not the subject of these installation and operating instructions.

Disregarding or misinterpreting these installation and operating instructions invalidates any product liability or warranty by RINGSPANN; the same applies if the product is taken apart or changed.

These installation and operating instructions should be kept in a safe place and should accompany the product if it is passed on to others – either on its own or as part of a machine – to make it accessible to the user.

Safety Notice

- Installation and operation of this product should only be carried out by skilled personnel.
- Repairs may only be carried out by the manufacturer or accredited RINGSPANN agents.
- If a malfunction is indicated, the product or the machine into which it is installed, should be stopped immediately and either RINGSPANN or an accredited RINGSPANN agent should be informed.
- Switch off the power supply before commencing work on electrical components.
- Rotating machine elements must be protected by the purchaser to prevent accidental contact.
- Supplies abroad are subject to the safety laws prevailing in those countries.

RINGSPANN	Installation and Operation Instruction for Integrated Freewheels FXM und FX Type NX, MX und LX			E 08.766e	
	Stand: 11.06.2018	Version : 02	gez.: BACC	gepr.: HEUT	Seitenzahl: 12 Seite: 3

Contents

1. General introduction
2. Applications of Freewheels
 - 2.1 Application as Backstop
 - 2.2 Application as Overrunning Clutch
3. Design
4. Types
5. General instructions
6. Condition at delivery
7. Technical requirements for safe operation
8. Installation
 - 8.1 Mounting
 - 8.2 Pull off the outer ring
 - 8.3 Check the existing run-out T.I.R.
9. Inspection prior to commissioning
10. Maintenance
11. Lubricants

1. General introduction

Integrated Freewheels FXM and FX are machine elements with particular characteristics:

- In one direction of rotation there is no contact between the inner and outer ring; the freewheel is in freewheeling operation.
- In the other direction of rotation there is contact between the inner and outer ring; in this direction it is possible to transmit high torque.

Integrated Freewheels FXM are used as:

- Backstops
- Overrunning Clutches



Caution!

As Freewheels can be used as safety components, it is important to observe these installation and operating instructions carefully.

2. Applications of Freewheels

2.1 Application as Backstop

Freewheels are used as backstops if reverse rotation of the operating direction is to be prevented. In many machines and installations, for technical safety or functional reasons, it is necessary to ensure that these are working in one specified direction of rotation only. For

RINGSPANN	Installation and Operation Instruction for Integrated Freewheels FXM und FX Type NX, MX und LX			E 08.766e	
	Stand: 11.06.2018	Version : 02	gez.: BACC	gepr.: HEUT	Seitenzahl: 12

example there are often legal requirements for the operation of conveyor systems existing that require a mechanical safety device.

The normal operating mode of a backstop is freewheeling operation; the locking (torque transmission) is performed at zero speed. The immediate engagement of the clamping elements ensures the required high operating safety.

2.2 Application as Overrunning Clutch

The overrunning clutch engages machines or machine parts and automatically interrupts their contact as soon as the driven part of the overrunning clutch is turned faster than the driving part. In many cases, this can replace a more expensive externally actuated clutch.

With overrunning clutches the engagement takes place in the driving operation (torque transmission), while in freewheeling operation the torque transmission between the inner and outer ring is interrupted. In driving operation the speeds of the inner and outer ring are equal, while in freewheeling operation they are different.

3. Design

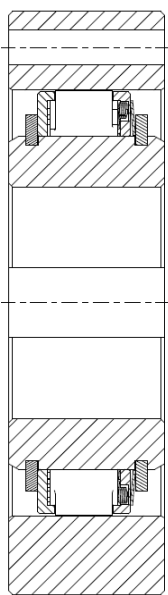

Fig. [1]: Type NX

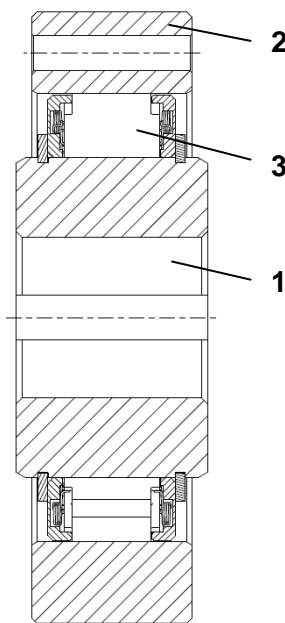

Fig. [2]: Type MX

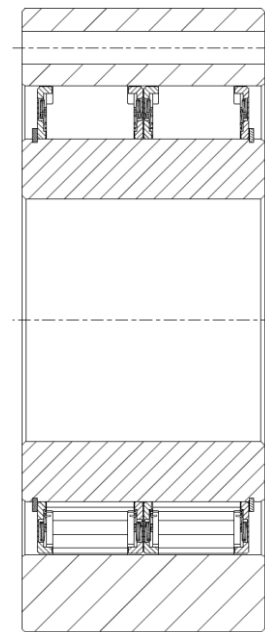

Fig. [3]: Type LX
(Model with 2 cages)

The Integrated Freewheels FXM, Type NX, MX und LX are designed as shown in Fig. [1-3]. The essential functional components are the inner ring (1) installed on the shaft, the outer ring (2) screwed onto a housing or a clutch and the sprag cage (3).

To establish a synchronization of the inner ring with the freewheel cage there is a frictionally engaged connection needed between the two parts. With the Types MX and LX this is achieved by bolts with friction pins in combination with disc springs. With the type NX this is ensured by a disc spring on the side between sprag cage and circlip on the inner ring.

The Integrated Freewheels FX have an identical setting but are supplied without the outer ring. For these freewheels the function of the outer ring must be ensured by the surrounding design.

RINGSPANN	Installation and Operation Instruction for Integrated Freewheels FXM und FX Type NX, MX und LX			E 08.766e	
	Stand: 11.06.2018	Version : 02	gez.: BACC	gepr.: HEUT	Seitenzahl: 12 Seite: 5

The properties of the sprag track must match the specifications in accordance with RINGSPANN Catalog "Freewheels".

Integrated Freewheels FXM are sprag-freewheels and have no bearing support. Concentric alignment of inner and outer ring is essential and must be provided by the customer. The freewheels are suitable in particular for the installation in housings with oil lubrication and sealing.

During normal operation the inner ring rotates together with the sprag cage. Above the lift-off speed the sprags take off from the stationary outer ring by centrifugal force. In this operating state, the freewheel works wear-free.

4. Types

Integrated Freewheels FXM and FX are available in type with "sprag lift-off X":

Type with "sprag lift-off X"

This type is designed for extended service life using sprag lift-off at high speed rotating inner ring.

It is identified by the suffix "X" at the end of the product designation.

Example: FXM 101 ... X and/or. FX 101 ... X



Please note!

Further information especially on design, function and selection, permissible torques or permissible speeds of these freewheels is provided in RINGSPANN Catalog "Freewheels". Please contact RINGSPANN GmbH if you need assistance.

5. General instructions



Caution!

Reliable torque transmission of the freewheel is guaranteed only if the maximum permissible speed in driving operation of the freewheel is not exceeded.

Operation at speeds in excess of the speeds permitted for the different operating modes can result in damage and overheating of the freewheel!

RINGSPANN	Installation and Operation Instruction for Integrated Freewheels FXM und FX Type NX, MX und LX			E 08.766e	
	Stand: 11.06.2018	Version : 02	gez.: BACC	gepr.: HEUT	Seitenzahl: 12 Seite: 6



Caution!

The maximum permissible freewheel torque must not be exceeded due to peak torques in specific applications.

The selection torque of the freewheel should be calculated according to RINGSPANN Catalog "Freewheels". Please contact RINGSPANN if you need assistance.

Freewheel damage resulting by excessive torque peaks impair component function and can result in excessive overheating of the freewheel!



Danger to life and limb!

When freewheels are used as backstops, it is essential to ensure that they can be released only when the machine or system is standing still and load-free.

Release of the freewheel under load conditions results in uncontrolled reverse movement of the system.



Caution!

The Integrated Freewheels FXM und FX are without bearing support. Concentric alignment of inner and outer ring must be provided by the customer.

The permissible run out (T.I.R.) must be observed!



Caution!

Torsion vibrations (amplitudes and frequencies which result in engagement and release of the freewheel in rapid succession) must be avoided.

Torsion vibrations can result in overheating and the impairment of freewheel function!



Caution!

Operation of freewheels with centrifugal sprag lift-off below the lift-off speed results in sprag wear. Occasional start and stop operations during operation below lift-off speed for periods of less than 20 second are permitted.

Excessive sprag wear can result in overheating and the impairment of freewheel function!

RINGSPANN	Installation and Operation Instruction for Integrated Freewheels FXM und FX Type NX, MX und LX			E 08.766e	
	Stand: 11.06.2018	Version : 02	gez.: BACC	gepr.: HEUT	Seitenzahl: 12 Seite: 7

6. Condition at delivery

The freewheels are delivered ready for installation. They are packed in anti-corrosion paper. Freewheels with the type of cage MX and LX are equipped with a transport lock starting from size 120.

Freewheels with the cage type LX can be supplied with loose outer ring, the outer ring then still needs to be installed. In this case the delivery includes a fastener strap, with which the sprags can be fixed in the lift-off position (see also Section 8.2).

The fastening screws necessary for the assembly with the attachment part are not part of the delivery. For the fastening screws a material quality of 8.8 is sufficient. Tightening torques are to be selected in accordance with VDI 2230 on the basis of the existing friction values in a given case.



Caution!

Screws with material grade 12.9 should not be used because of their low breaking elongation.

7. Technical requirements for safe operation

The bore in the inner ring normally has a tolerance of ISO H7. The tolerance of the shaft must be in this case ISO h6 or j6.

The key must have clearance in height to the key groove and may have only minimal width over-size, as otherwise the inner ring may be deformed.



Caution!

The transmittable torques are combined with the permissible run out (T.I.R.) between the shaft and outer ring sprag track in accordance with RINGSPANN Catalog "Freewheels".

Compliance with the permissible run out must be guaranteed by the design of the bearing support and centering of the freewheeling parts.

Make sure that the axial position of the inner ring with the freewheel cage after mounting will be in a way that in each case between sprag cage and end of the centering collar, a minimum distance of $b = 2 \text{ mm}$ is existing, see Fig. [5]. The same applies to the opposite side.

A protection against dust, pollution and humidity must be provided.

Depending on the operating data an oil or grease lubrication has to be provided (see also Section 10 "Maintenance" and Section 11 "Lubricants").

RINGSPANN	Installation and Operation Instruction for Integrated Freewheels FXM und FX Type NX, MX und LX			E 08.766e	
	Stand: 11.06.2018	Version : 02	gez.: BACC	gepr.: HEUT	Seitenzahl: 12 Seite: 8

8. Installation

8.1 Mounting

- Prepare the fastening screws for the outer ring and check that the quantity, size and grade are correct.
- The direction of machine or system rotation must be determined prior to freewheel installation. Mark this direction with an arrow on the shaft to which the inner ring of the freewheel is to be mounted.
- Ensure that the freewheeling direction of the freewheel matches the direction marked on the shaft.
- Clean the mounting surface and the centering spigot for the outer ring on the housing or the intermediate flange carefully and clean the shaft area for the inner ring.
- Unpack the Integrated Freewheel and remove the packaging but without pulling off the outer ring. Apply a coat of acid-free, aging resistant, light machine oil to all components of the Integrated Freewheel to protect it against corrosion.
- For an easier mounting the Integrated Freewheel or the inner ring with sprag cage may be heated up to max 100°C.
- If using a sealing compound between fastening surface and face of the outer ring ensure that it is applied sparingly and evenly distributed.



Caution!

Excess of the sealing compound must not to enter the sprag cage.

- Push the Integrated Freewheel carefully onto the shaft until it is located against the shaft shoulder or the distance ring . **For a possibly necessary removal of the outer ring please refer at this point to Section 8.2.**



Caution!

When mounting the inner ring onto the shaft, pressure should only be applied on the face of the inner ring; never apply force to the sprag cage or use a hammer!

- Continue by mounting the axial fastening for the inner ring – illustrated in the Fig. [5] as a cir-clip, for example. Other designs of an axial lock are possible.



Caution!

When a freewheel is used as a backstop, the drive must not be started in the locking direction of the freewheel, otherwise the freewheel may be destroyed!

- Assemble the outer ring onto the centering spigot and screw it to the fastening surface, together with the cover, if applicable.

RINGSPANN	Installation and Operation Instruction for Integrated Freewheels FXM und FX Type NX, MX und LX			E 08.766e	
	Stand: 11.06.2018	Version : 02	gez.: BACC	gepr.: HEUT	Seitenzahl: 12 Seite: 9

8.2 Pull off the outer ring

If for assembly reasons by Type LX, the outer ring must be separated from the inner parts (inner ring with cage), e.g. for grease lubrication (see Section 10 „Maintenance“ and Section 11 „Lubricants“), act as follows:

- Stop removing the outer ring if a minimum of 20 mm of the sprags are left in the outer ring (see Fig. [4]). Secure the outer ring in this position.
- Put the fastener strap around the sprags and tight them.
- Now the outer ring is free removable.
- For a unit with two cages you have to practice these steps twice.

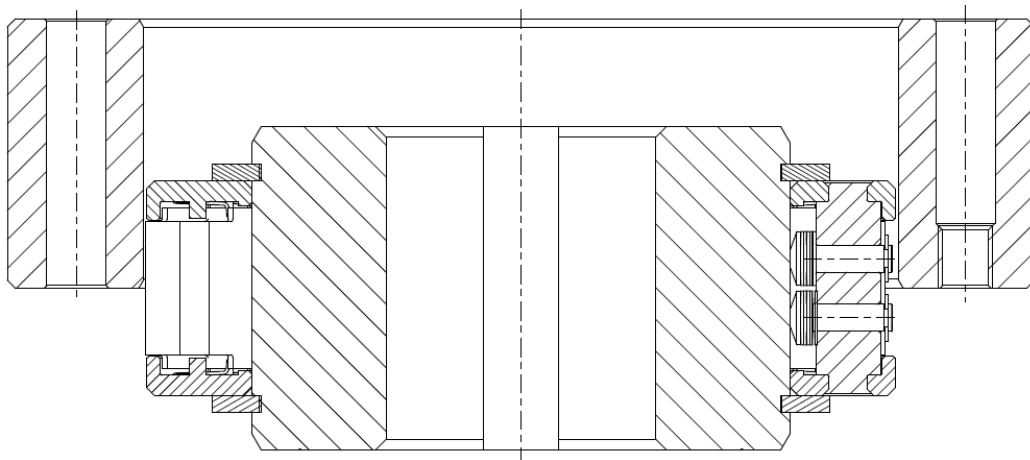

Fig. [4]: Removing the outer ring from the sprag cage

Note: Just in case the outer ring has been removed from the sprag cage without using the fastener strap, all sprags must be turned against the spring force in lift-off position and be fixed with the fastener strap. Assembling the outer ring onto the sprag cage while the sprags are turned up by the springs is not possible!

Note: This method can also be used for the type DX or SX. Use instead of the fastener strap a suitable O-ring or similar.

8.3 Check the existing run-out T.I.R.

The most reliable check of existing run-out between shaft and outer ring can be only performed when both the outer ring and inner ring with cage are mounted. The cover should not be assembled at this point but the outer ring must be fixed along its whole mounting face against the fastening surface by the fastening screws.

There are several methods for checking run-out, one of these is described here.

- Fasten a dial gauge to the inner ring and locate the sensor of the dial gauge against the bore of the outer ring (point U in Fig. [5]).

- Slowly turn the shaft 360° and determine the maximum run-out (T.I.R) whilst ensuring (particularly in the case of taper or sleeve bearing applications) that the bearing play is included in the run-out.
- Compare this run-out value with the permissible value given in the documents of the machine.

Alternative the maximum radial run-out (T.I.R) can be determined by measuring the distance between the inner- (1) and outer ring (2). The measurement has to be done all 90 ° at the circumference with a internal measuring device e.g. " Intertest". The largest difference of the results of measurement lying in a line, is the run-out (T.I.R).

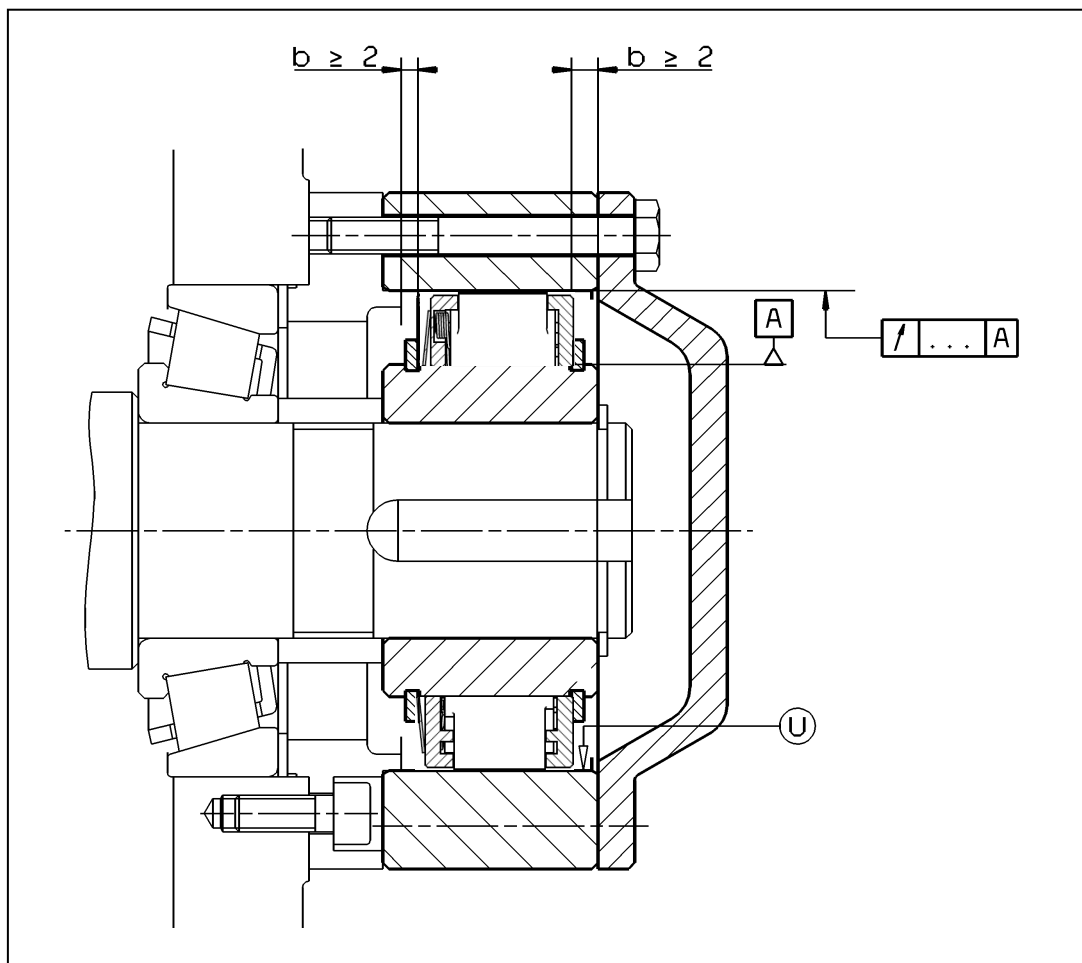

Fig. [5]: Measuring the run-out (T.I.R) (example)

9. Inspection prior to commissioning

Before operating the freewheel you have to make sure, that the shaft can be easily and evenly turned in freewheeling direction.

10. Maintenance

When freewheeling above the lift-off speed, the freewheels operate in maintenance free mode and do not require lubrication. Protection against corrosion has to be provided.

For the occasional starting and stopping operation (running time max. 20 s below lift-off speed) splash lubrication of the races is suffice. Is oil mist existing, so is this sufficient.

RINGSPANN	Installation and Operation Instruction for Integrated Freewheels FXM und FX Type NX, MX und LX			E 08.766e	
	Stand: 11.06.2018	Version : 02	gez.: BACC	gepr.: HEUT	Seitenzahl: 12 Seite: 11

If no oil will reach the outer ring sprag track, a grease lubrication is to carry out as follows

- thickness of film approx. 0.5 mm,
- with a mineral lithium-based lubricant of NLGI classes 000 to 2 with a maximum base viscosity of 42 mm²/s at 40 °C (low temperature grease such as “LBZ” lubricant by Mobil or “ISOFLEX LDS 18 spezial A” by Klüber).

Caution! Too much grease will lead to malfunction of the freewheel!

With frequent or constant operation below the lift-off speed (please contact RINGSPANN directly with RINGSPANN part number if available or see specific order documentation) either an oil bath or an oil supply between cage and outer race is necessary. The corresponding volume flow can be found in Table 1. Even so, the service life under such conditions is limited!

Freewheel description	Quantities of oil
FX / FXM ... NX	50 cm ³ /min
FX / FXM ... MX	100 cm ³ /min
FX / FXM ... LX	200 cm ³ /min

Table 1: **Quantities of oil**



Please note!

If you need additional information, for example regarding need of life below the lift-off speed, please ask directly at the RINGSPANN GmbH.

11. Lubricants

We recommend the following grades of oil for lubrication or oil changes:

Oil table			
Ambient temperature	For ambient temperatures from 0° to 50° C	For ambient temperatures from - 15° to + 15° C	For ambient temperatures from - 40° to 0° C
Kinematic viscosity at 40° C, ISO-VG	46/68 [mm²/s]	32 [mm²/s]	10 [mm²/s]
AGIP	OSO 46/68	OSO 32	OSO 10
ARAL	VITAM GF 46/68	VITAM GF 32	VITAM GF 10
BP	ENERGOL HLP 46/68	ENERGOL HLP 32	AERO HYDRAULIC 1
CASTROL	VARIO HDX	VARIO HDX	ALPHASYNTH 15
CHEVRON	EP HYDRAULIC OIL 46/68	EP HYDRAULIC OIL 32	HYJET IV
DEA	ASTRON HLP 46	ASTRON HLP 32	ASTRON HLP 10
ELF	ELFOLNA 46	ELFOLNA 32	ELF AVIATION HYDRAULIC OIL 20
ESSO	NUTO H 46/68	NUTO H 32	UNIVIS J 13
KLÜBER	LAMORA HLP 46/68	LAMORA HLP 32	Klüberoil 4 UH1-15
MOBIL	D.T.E. 25/26	D.T.E. 24	AERO HF A
SHELL	TELLUS OIL 46/68	TELLUS OIL 32	TELLUS OIL 10
Other manufacturers	Gearbox- or hydraulic oils without solid lubricants ISO-VG 46/68	Gearbox- or hydraulic oils without solid lubricants ISO-VG 32; Automatic transmission fluids [ATF]	Gearbox- or hydraulic oils without solid lubricants ISO-VG 10; Note setting point! Aviation hydraulic oils ISO-VG 10

Please contact us if temperatures exceed + 50 °C or fall below – 40 °C.

For grease lubrication we recommend the following greases for ambient temperatures of -15 °C to + 50 °C:

ARAL	ARALUB HL2
BP	ENERGREASE LS2
ESSO	BEACON 2
MOBIL	MOBILUX 2

KLÜBER	ISOFLEX LDS 18 Spezial A
	POLYLUB WH 2
SHELL	ALVANIA RL2